

AUTHORIZED DEALER

www.jobsite technologies.com



**MOBA-MATIC &
BIG SONIC-SKI**

MOBA[®]
MOBILE AUTOMATION

HOW TO GET RID OF ROAD WAVES - A MAJOR PROBLEM WHEN RECONSTRUCTION OR RENOVATING ROADS

In road construction, particularly in road reconstruction and renovation, a major problem occurs after having milled the surface. Significant unevenness evokes road waves in large areas of the road, which increasingly impairs road quality. The solution, however, is a system that considers large sections of the ground to monitor bumpy passages and perfectly level them out, such as the unique combination of the two leveling systems MOBA-matic II and Big Sonic-Ski.

4 ultrasonic sensors enables you to sense nearly all surfaces, irrespective of their condition. Even irregularities within a ground section of up to 6 meters will be reliably smoothed. The more Sonic-Skis are integrated into the system, the more precise the leveling gets.

**BIG SONIC-SKI
SMOOTHNESS
X-TENDED**





**NEW ASPHALT
SURFACE WITH
PERFECT SMOOTHNESS**

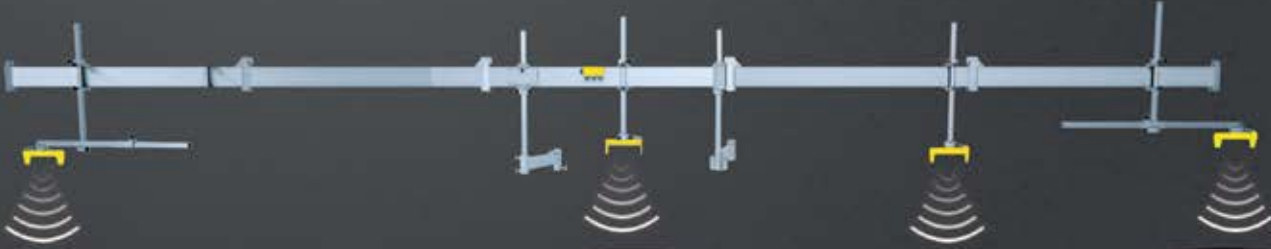

www.jobsite technologies.com

Leveling to the highest standard

03



MOBA-MATIC - THE MOST VERSATILE CONTROL SYSTEM IN THE WORLD

SYSTEM- BENEFITS

- » Largest selection of sensors anywhere
- » Modular system allows multiple combinations
- » Easy to install
- » High-precision, dependable results
- » 3D-capable (GNSS and Total Station positioning solutions)
- » CAN communication technology
- » One system can be used on many machines



Thanks to the extreme modularity of the system you can flexibly combine a wide range of sensors to achieve optimum results for your specific project. The system always adapts perfectly to your personal needs and can be time- as well as cost-efficiently be adjusted or upgraded anytime! With the practical two-in-one control panel, which includes a controller as well as operating unit in one housing, operation is not only easy but also time-efficient.

For more than 30 years, the MOBA-matic thus has proven itself as the first choice in road construction when precision, usability and efficiency matter.

MOBA-MATIC II CONTROLLER THE "HEART" OF THE SYSTEM



www.jobsitetechnologies.com

GRADE SENSOR SONIC-SKI

- » Five ultrasonic contact-free sensors scan the reference surface
- » Extremely precise distance measurement by means of averaging
- » CAN-interface



01

DIGI SLOPE SENSOR

- » Especially designed for high vibration screeds
- » Slope angle display available simultaneously with level information
- » Simple and easy to recalibratable



02

LACER RECEIVER LS-3000

- » Compatible with all common rotating laser transmitters for machine control
- » Digital linear detection of the laser beam
- » No electrical mast required for height adjustment
- » Reference point user selectable with a single button press



03

DIGI ROTARY SENSOR

- » Can be used under all climatic conditions
- » Operates in stringline and ground sensing modes



04

WIRE ROPE SENSOR

- » Very precise height position measurement for milling applications
- » The user can easily replace the steel wire (wearing part)
- » Measuring range: 500 mm

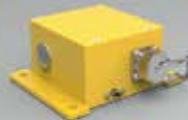

05

IR TEMPERATURE SENSOR

- » Measurement of material temperature
- » Installation in the hopper or behind the screed
- » Temperature information in real time at MOBA-matic II



06

BIG SONIC-SKI - EASY MOUNTING FOR FASTER RESULTS

The Big Sonic-Ski is a unique 4-sensor solution on the paving market and guarantees extraordinary results in paving quality. Unevenness that fails to be detected by only three sensors are easily leveled out with the Big Sonic-Ski. Not only does it increase smoothness and road quality but also is it easily installable, user-friendly and extendable to up to 13 meters.

The flexible mounting and quickly adjustable positions of the four sensors additionally increase maneuverability of the paver and guarantee the perfect surface in curved roads. It is thus always perfectly equipped even in troublesome environments.

SYSTEM BENEFITS

- » High precision thanks to constant averaging of measurements of 4 independent sensors
- » Time saving due to user-friendly mounting and operation possibilities
- » Increased smoothness by monitoring large sections of the ground

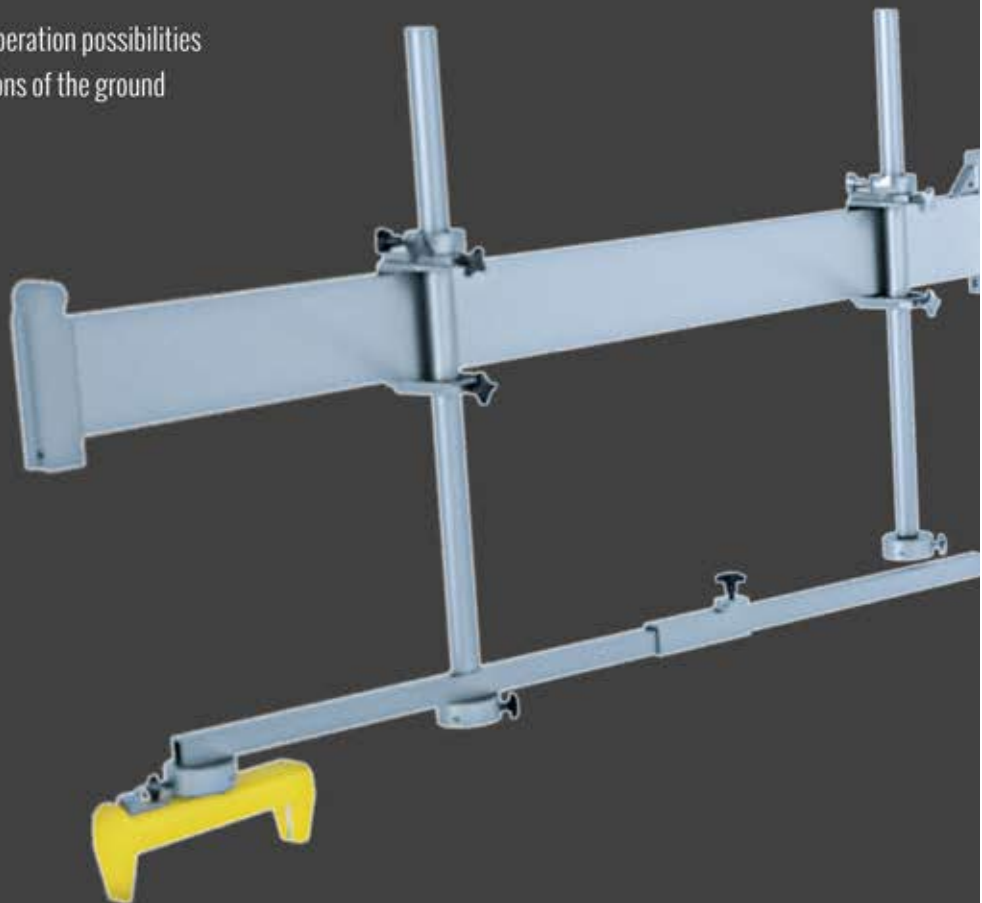

BIG SONIC-SKI - LONG-RANGE AVERAGING VIA

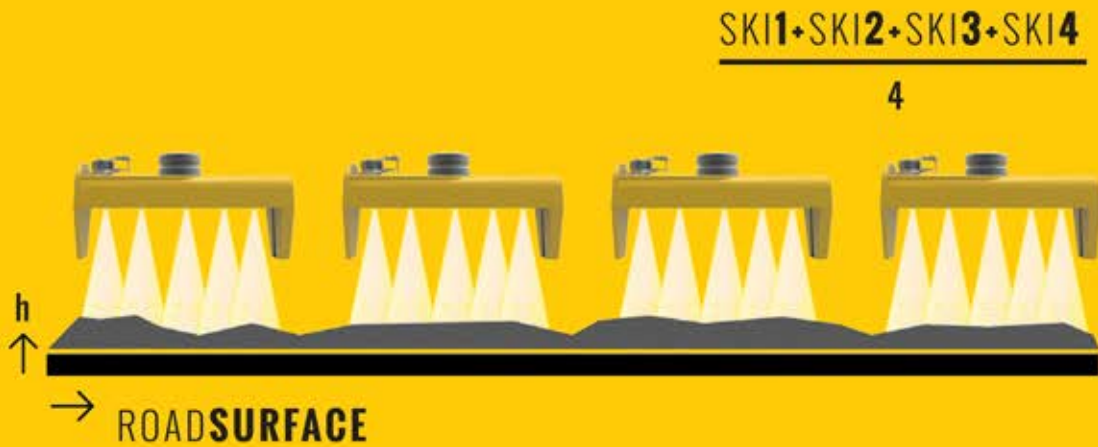

LONG-RANGE AVERAGING VIA

- » Combines the positive effects of four Sonic-Ski plus sensors
- » Multiple integrated scanning across the whole reference
- » Provides a long range continuous virtual level reference
- » Unevenness over longer stretches is also corrected



Corporate
Joey Farrell
CEO/President

11100 Jacqueline Ave
Englewood, FL 34224
Office: 941-460-0250
Fax: 941-460-0251
Cell: 678-588-1584
farrell.joey@gmail.com

Southeast Division
Bryan Abernathy
Regional Sales Manager

8844 Mt. Holly Rd
Charlotte, NC 28214
Cell: 704-564-8333
bryanabernathy.jst@gmail.com

www.jobsitetechnologies.com

Leveling to the highest standard

07

MOBA
MOBILE OPERATING SYSTEM